

# Powered Attenuators

## Customised case with inbuilt fans



Powered Rectangular Attenuators are NCS/ NCT/NSM/NTM Rectangular Attenuators with customised cases and inbuilt fans. For use where additional ventilation and sound level control is required.

Insertion loss and pressure loss dependant on design.

- Manufactured to individual requirements and can be designed to match specific equipment or exit conditions.
- Galvanized steel or stainless steel construction.
- Powder-coated or epoxy paint finishes, available in a range of colours.
- Melinex lining available.
- Ideal for room pressurisation applications.

Data correct at time of publication, please ensure you have the latest version by checking our website. NCS Acoustics Limited accepts no liability for use of data within this brochure. Materials may be updated at any time without notice.

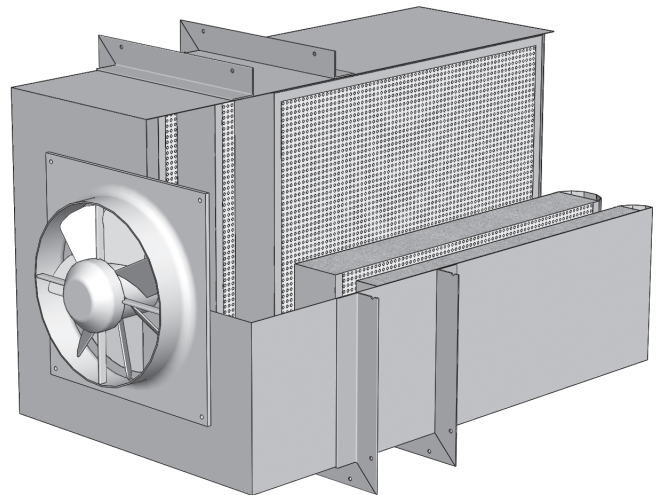

**For more information see the NCT/NCS/ NSM/NTM Rectangular Attenuators brochures and contact us.**